

NS形 挿し受片落管

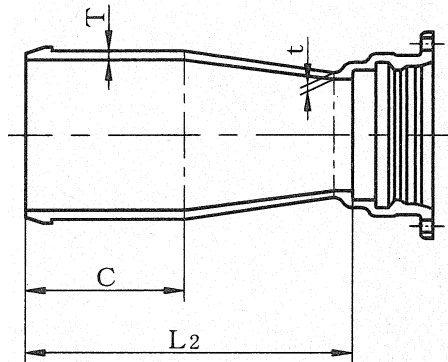

呼び径 300~450



単位 mm

呼び径		管厚		各部寸法		質量 (kg)
D	d	T	t	C	L ₂	
300	100	12.5	10.0	235	735	55.6
300	150	12.5	11.0	235	635	59.5
300	200	12.5	11.0	235	535	60.9
300	250	12.5	12.0	235	435	61.2
350	150	13.0	11.0	240	740	74.0
350	200	13.0	11.0	240	640	75.2
350	250	13.0	12.0	240	540	75.7
350	300	13.0	12.5	240	375	71.7
400	150	14.0	11.0	255	855	94.1
400	200	14.0	11.0	255	755	95.0
400	250	14.0	12.0	255	655	95.5
400	300	14.0	12.5	255	490	91.3
400	350	14.0	13.0	255	395	87.7
450	200	14.5	11.0	255	855	114
450	250	14.5	12.0	255	755	115
450	300	14.5	12.5	255	590	111
450	350	14.5	13.0	255	495	107
450	400	14.5	14.0	255	395	104

JWWA G 114

JSWAS G-1

JDPA G 1042

による。

品名	NS形 片落管 (挿し受片落管)			
尺度	非比例	第三角法	日付	
 朝日鑄工株式会社				